

313, 313B Low-Profile Microwave Detector

The Low-Profile Microwave Detector provides occupancy detection for the automatic control of DALI lighting loads. The unit can also be controlled using a Helvar infrared remote handset, such as the 303 DIGIDIM Infrared Remote Control.

Helvar's 313 detects movement using its highly sensitive microwave detector. It works by emitting low-power microwave signals and measuring the reflections as the signals bounce off moving objects.

When an area is no longer occupied, the load will switch off after a certain time. This time-out period is configured using Helvar's lighting system design and control software: Designer, or Toolbox.

Features and Connections

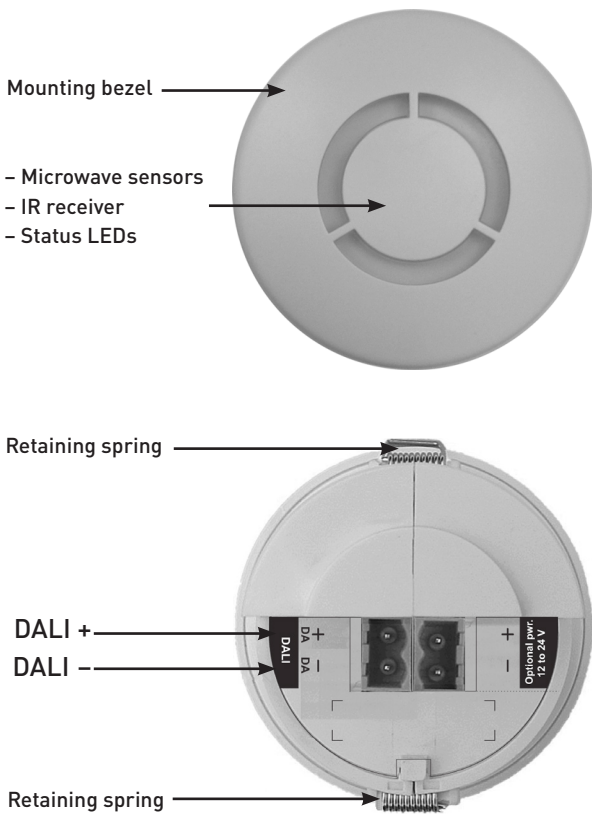

Microwave sensor

Detects movement within the detection range allowing load control in response to changes in room occupancy.

IR Receiver

Receives control and programming commands from a Helvar infrared remote handset (available separately).

Status LED

The red LED flashes to indicate the following:

Valid setting received	
Identify active	

= Red LED

Optional connection to external power

12 V to 24 V. See 'External Power Supply (Optional)' on page 3.

DALI connection

The DALI connection is made via DA+ and DA- terminals. The DALI input is not polarity sensitive (unless you are using an external power supply).

Detection Pattern

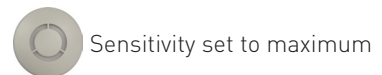
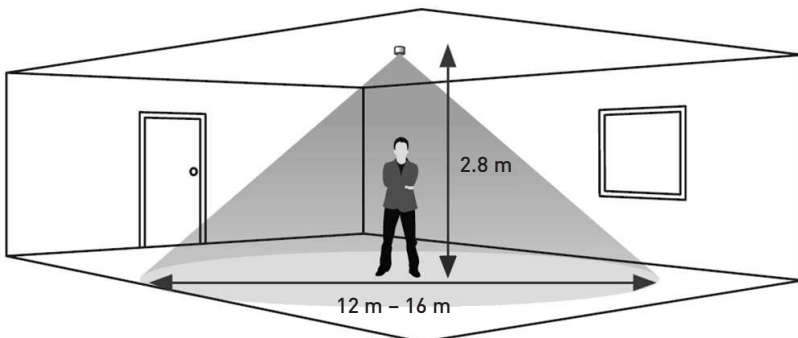

1. Install the unit: see 'Connection and Fixing' on page 2.
- 2a. Connect the DALI terminal blocks to the sockets located at the rear of the sensor.
- 2b. If required, connect the optional power supply. See 'External Power Supply (Optional)' on page 3.
3. Power the unit up.
4. After the lighting load switches on, by default it will switch off after 20 minutes of no movement detected.

Installation Notes

- Position the sensor so that the occupants of the room are normally inside the detection zone.
- Do not install the sensor within 1 m of any lighting, forced air heating, or ventilation equipment.
- Do not fix the sensor to an unstable or vibrating surface.
- Install the unit as far away as possible from the surface of metal objects.
- The detection pattern illustrated (see 'Detection Pattern' on page 1) is based on a mounting height of 2.8 m. A lower mounting height will decrease the overall size of the detection zone.

Connection and Fixing

Mounting hole

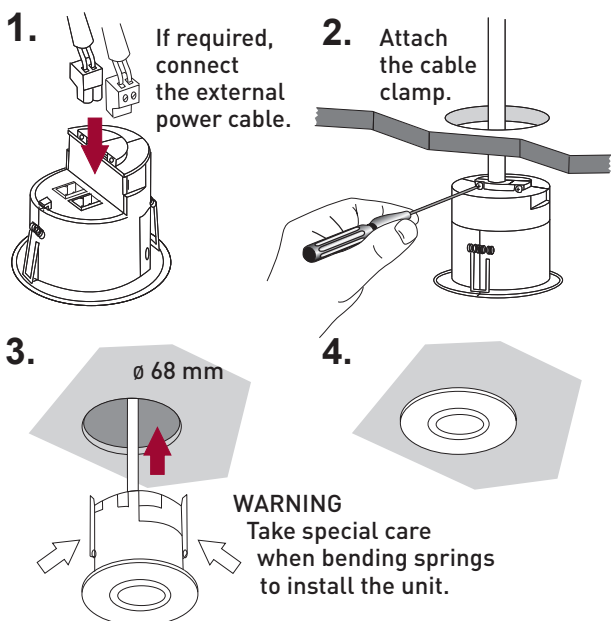

Surface Back Box SBB-A, SBB-AB

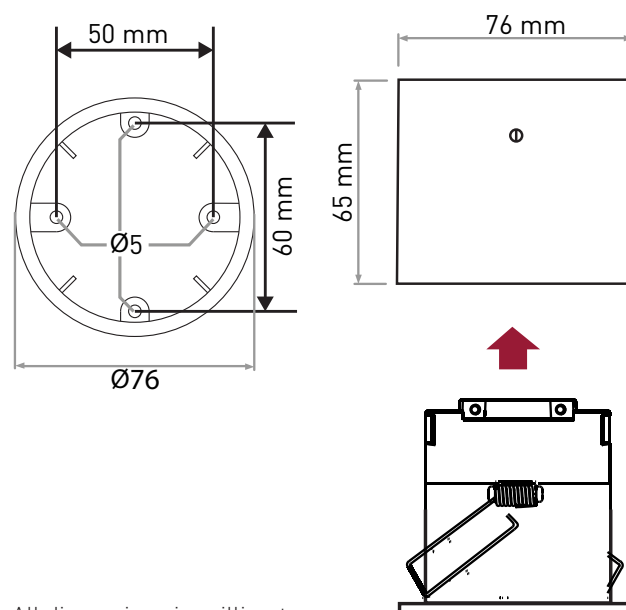

All dimensions in millimetres.

Note: Order the SBB-A or SBB-AB surface mount boxes separately.

External Power Supply (Optional)

The following table gives the various 12 V to 24 V external power supply units that can be used, as well as the sensor hardware revision needed for each of them. With some models, you must make a wire link between the DALI negative terminal and the negative terminal of the external power supply, as shown in the figure.

EPS	Current limited	Link from DA- to EPS-	Sensor hardware revision
Helvar 401	Yes	No	Any
Helvar 402	Yes	Yes	Any
Helvar 403	Yes	No	Any
Helvar LL1x30-E-CV24	Slow	No	4 or later
Generic 12 V to 24 V	No	No*	4 or later

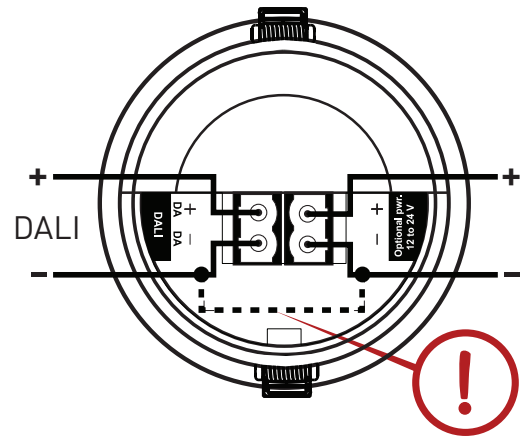

* Except in some cases where the generic EPS output is referenced to earth.

Remote Control

You can use a Helvar infrared remote handset, such as the 303 DIGIDIM Infrared Remote Control, to send signals to the 313 Detector to:

- Recall lighting scenes 1-4.
- Adjust light levels.
- Store current level.
- Install preset levels for scenes 1-4.



303 DIGIDIM Infrared Remote Control
For details, see the 303 *Installation and User Guide*.

Other Functions

Sensitivity

Adjust the sensitivity using Designer, or Toolbox (Helvar's lighting system design and control software).

Note: On maximum sensitivity, the detector unit is **extremely sensitive** to movement and may detect through glass, thin walls or partitions. If this causes a problem, reduce its sensitivity.

Adjusting On, Exit and Transition Time-Outs

The default time-outs for On, Exit and Transition can be altered using Designer, or Toolbox.

Check Connection to DALI Network

To make sure that the sensor is correctly connected the DALI network, use the *Identify* function in Designer, or Toolbox.

Using Designer and Toolbox Software

When using Designer, connect the PC to the lighting network via a Helvar router.

When using Toolbox, connect the PC to the lighting network via a Helvar serial or USB interface.

For information about Designer and Toolbox, visit www.helvar.com.

Connections

External power / DALI: Removable terminal block
Wire section: 0.5 mm² – 2.5 mm²
solid or stranded

Cable rating: All cables must be mains rated.

Power

DALI supply input: 13 V to 22.5 V

DALI consumption: 20 mA
Note: DALI consumption is less than 2 mA when external power is supplied to the unit.

(Optional) External power: 12 V to 24 V; 0.3 W

Remote control functions

Use Helvar infrared remote handset to:

- Recall lighting scenes 1–4.
- Adjust light levels.
- Store current level.
- Install preset levels for scenes 1–4.

Note: Adjust sensitivity using Designer, or Toolbox (not by remote control unit).
Factory setting for sensor sensitivity: 9 (maximum).

Microwave operating frequency

Frequency: 5.8 GHz

Mechanical data

Mounting hole diameter: 68 mm

Bezel diameter: 76 mm

Recommended clearance depth (incl. 50 mm for cabling): 80 mm (without protective cover)
100 mm (with protective cover)

Material (casing): Flame retardant ABS and PC/ABS

Finish/Colour: **313:** Matt / White RAL 9003

313B: Matt / Anthracite Grey RAL 7016

Weight: 90 g

IP code: IP30

Operating conditions

Ambient temperature: 0 °C to +50 °C

Relative humidity: Max. 90 %, noncondensing

Storage temperature: –10 °C to +70 °C

Conformity and standards

EMC emission: EN 61000-6-1

EMC immunity: EN 61000-6-3

Safety: EN 60730-1

Environment: Complies with WEEE and RoHS directives.

Version information

Software version: 6

Hardware version: Rev. 4

Software compatibility

Designer: 4.1 or later

Toolbox: 2.2.16 or later

Dimensions

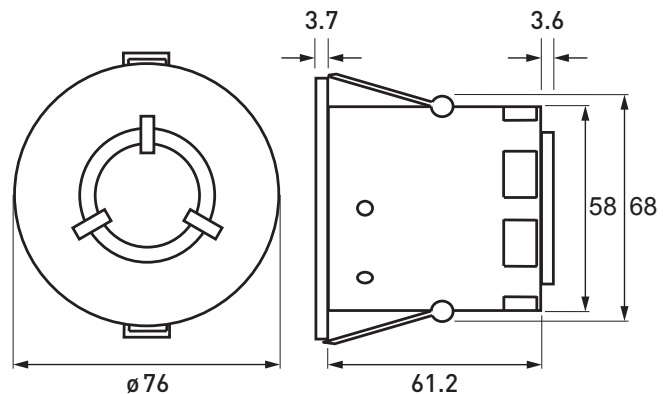

Helvar Ltd
Hawley Mill
Hawley Road
DARTFORD
DA2 7SY
UNITED KINGDOM
www.helvar.com